

**Montana State University
Solar Vehicle Project**

David M. Caditz, Ph.D.

**Department of Physics
Montana State University**

Summary

The Montana State University Solar Vehicle Project is a student organization dedicated to promoting efficient, environmentally clean transportation technologies. We are designing and building a world-class solar powered race vehicle which will be entered into competition with similar vehicles built by companies and universities throughout the world. We will promote pollution-free technologies through public displays and demonstrations of our vehicle, media events, and presentations in educational institutions at all levels. We provide unique educational opportunities within the Montana University system for students, faculty, and staff.

The Montana State University Solar Vehicle Project relies solely on donations of materials, services, and funds from interested companies and individuals from within Montana and across the country. The benefits to our sponsors are many - they include the formation of close links to Montana State University, contact with skilled and motivated students who could be potential future employees, widespread advertisement opportunities, local, state-wide, and national publicity, and the benefits of doing something good for the environment.

The purpose of this proposal is to document our competence and our motivation to produce a successful solar powered race vehicle. Although space limits our discussion to a few of the more important aspects of solar vehicle design, we hope to convey a comprehensive plan for construction and racing of a successful vehicle. In section 1, we describe our general approach to the problem of building and racing a solar vehicle. We describe the factors that have influenced us in our design and organizational decisions, including successes and failures of previous solar race vehicles. In section 2, we describe the design of our race vehicle as well as the materials and fabrication methods to be used. We point out some design innovations which have not yet been applied to solar powered or other types of high efficiency vehicles. Section 3 describes our solar array design and manufacturing procedures. In section 4 we discuss vehicle testing, driver training, and race strategy. Section 5 describes our fundraising efforts and section 6 outlines our organizational structure. We include short resumes of our project members.

Forward

In the eighty-three years since the first Model "T" Ford rolled off of the assembly line, a total of 5 billion gasoline powered automobiles have been built. The impact of mass produced personal vehicles has been enormous, allowing almost unlimited freedom of mobility for millions of people worldwide. It has become increasingly clear, however, with declining fuel supplies and detrimental environmental effects of oil exploration, refining, and consumption, that the benefits of gasoline powered vehicles are transitory - we cannot continue to rely on combustion powered vehicles into the indefinite future.

The record setting 1987 General Motors "Sunraycer" - a prototype solar powered vehicle - had impressive performance specifications in excess of its gasoline powered predecessor of 80 years ago: Ten horsepower, 0 to 50 in 25 seconds, maximum speed 82 miles per hour. The Sunraycer, like a small number of similar vehicles built by companies, schools, and backyard mechanics, uses sunlight as fuel, and produces zero pollution. Like the fastest gasoline powered race cars of the early century, these efficient, light weight solar racers may signify the dawn of a new era of clean, quiet, ultra-efficient, electric powered transportation.

This year, Montana State University joins a small group of organizations who are building and racing solar cars. By summer of 1995, the Montana State University Solar Vehicle Project (MSUSVP) will be entering a world class solar racer into national and international competition. MSU's solar car is described in detail in this proposal. I encourage anyone interested to contact the MSUSVP for more details about the car or our project in general.

The MSUSVP is an all volunteer project and we will be operating on a shoe-string budget. Montana's solar car will not be built without your help. We rely on the advice and generous donations of local and national businesses and interested individuals. While the technical problems associated with building a solar car are immense, raising funds to support the project presents an even greater challenge. We encourage you to consider your donation as an investment in environmentally clean transportation technologies. The MSU engineering students designing solar race cars today will be the engineers designing the efficient, quiet, emission free vehicles which we must be driving tomorrow.

David Caditz, Ph.D.
Faculty Advisor

Table of Contents

Critical Design Factors for Solar Vehicles.....	2
Vehicle Design.....	7
Body design.....	7
Aerodynamic analysis.....	9
Suspension.....	10
Brakes.....	11
Chassis.....	11
Motor and drivetrain.....	13
Power, monitoring, and control electronics.....	14
Batteries.....	14
Maximum power trackers.....	15
Auxiliary 12 volt system.....	16
Integrated control board.....	16
Driver controls and instrumentation.....	16
Solar array.....	18
Vehicle testing, driver training, and race strategy.....	22
Fundraising.....	23
Project Organization.....	25
Member Resumes.....	25

I. Critical Design Factors for Solar Powered Vehicles

In his 1987 article "How Design Factors Affect Solar Car Race Performance", Dr. Chester Kyle identified four design factors critical to solar vehicle performance, and he placed them in the following order of importance:

- 1) Panel power
- 2) Aerodynamics
- 3) Vehicle weight
- 4) Rolling resistance.

This ordering applies to a long distance (> 1000 km) race in favorable weather conditions such as might be expected in Australia in November. If, on the other hand, cloudy weather prevails, then average speeds will be lower, and vehicle aerodynamics will carry less relative importance. Such adverse conditions existed during the General Motors Sunrayce (Florida to Michigan, July 1990), and cars with large surface area solar arrays capable of collecting relatively more diffuse light tended to perform better than "flat panel" cars with smaller array area, regardless of aerodynamic efficiency. An example would be the Stanford "SUnSUrfer" which placed fifth in the single seat class, though it was designed with little regard to aerodynamics, and must actually have had one of the highest drag coefficients among the 32 competitors.

Dr. Kyle's critical design factors address the solar vehicle only as a "finished product", and it is useful to identify other factors critical to the success of such a project from inception to race finish. Such a list might include:

- 1) Adequate construction time
- 2) Adequate manpower
- 3) Effective time and resource management
- 4) Adequate financial resources
- 5) Vehicle reliability testing
- 6) Vehicle performance modeling
- 7) Effective race procedures
- 7) Effective strategy implementation
- 8) Race experience

The importance of the items on this list have been made painfully obvious by the failure of many solar vehicle teams to build competitive vehicles regardless of the resources available to them, or to effectively race vehicles which were indeed competitive according to the standards listed by Dr. Kyle. A prime example of the latter is the University of Maryland's "Pride of Maryland" which, according to Richard King of the US Department of Energy was the fastest car in the GM Sunrayce, and one of the fastest in the 1990 World Solar Challenge, yet which placed third and seventh in the two races, respectively, due to tactical errors, mechanical failures, and race team disorganization.

Figure 1 is a graph of power to weight ratio vs. finishing time for the top 11 single passenger competitors in the 1990 Australian World Solar Challenge. Power to weight ratio is a useful indicator of potential performance, and if each car were run at its full potential, power to weight and finishing time would be correlated. Figure 1 shows some such correlation, however, there are notable exceptions. Most notable are the Michigan, AERL, and Barossa cars which finished well ahead of several cars with higher power to weight ratios, and the Monash, Pomona, and Kyocera vehicles which under-performed based on this statistic.

It is useful to investigate reasons for the performance levels of vehicles which deviated from their expected power to weight ratio performance levels. Figure 2 is a plot of time lost due to mechanical failures vs. finishing time. Hoxan, for example, lost 2.5 race hours due the failure of two drive motors. Maryland had a frame failure and electrical problems. These two cars would clearly have placed higher (second place for Hoxan, sixth for Maryland) had their vehicles been more reliable. Pomona lost an estimated six hours due to drive train problems and wheel

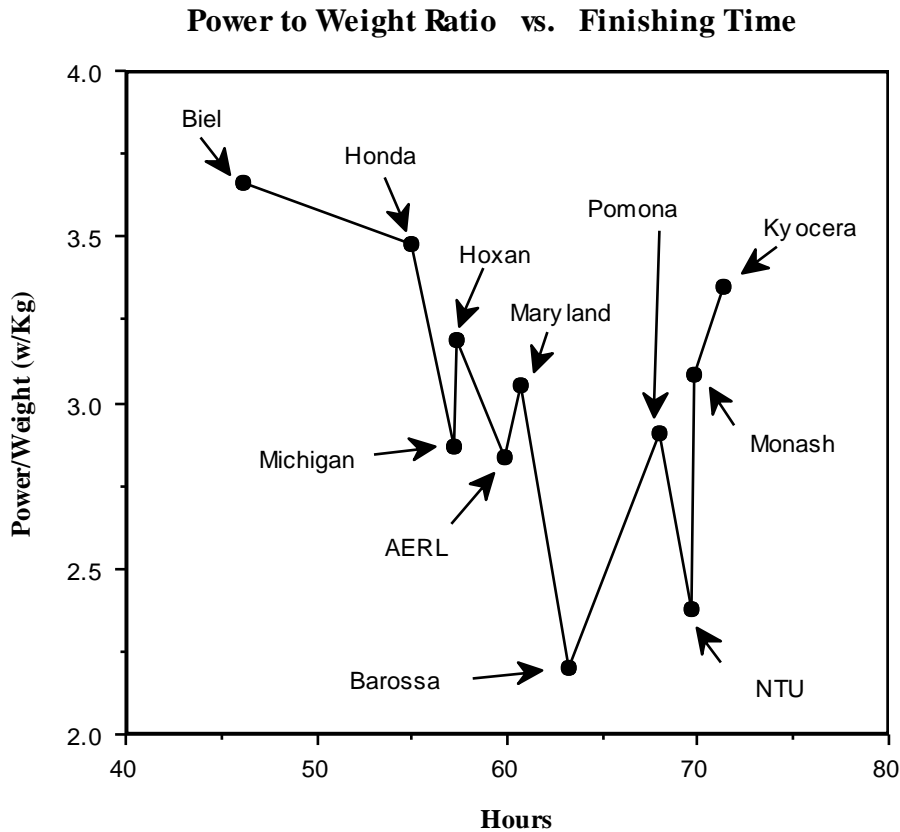

Figure 1

Time Lost Due To Mechanical Failures

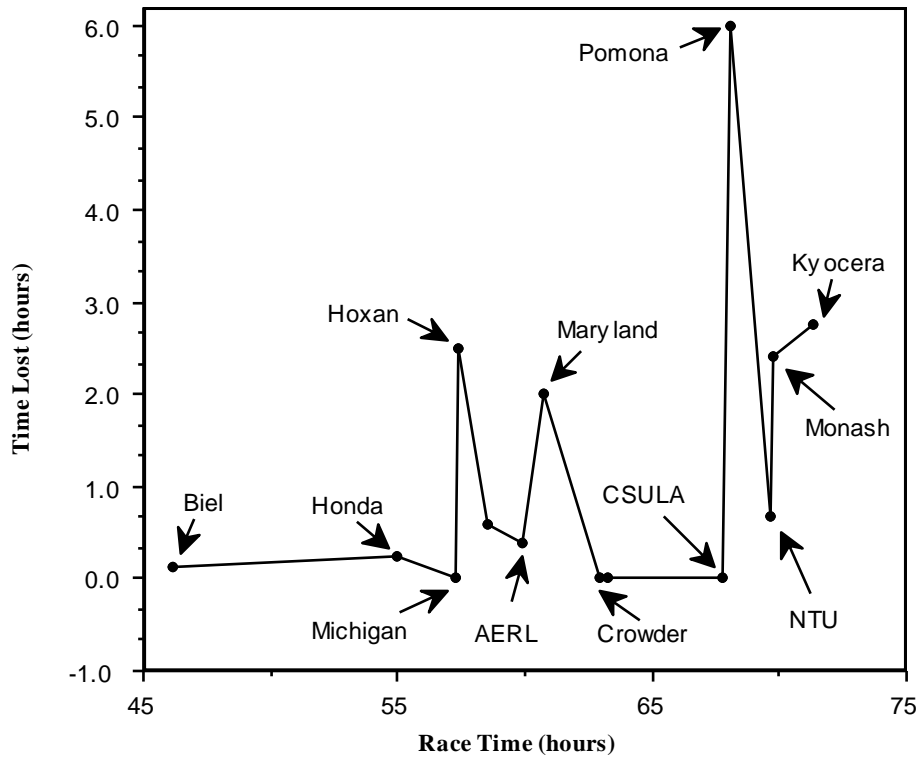

Figure 2

misalignment. Kyocera broke a suspension component (1.5 hours lost) and had several battery cells fail. Honda also broke a suspension component, however, due to well organized and practised repair procedures, lost only 15 minutes in the repair. Michigan placed third with a heavy, yet highly reliable vehicle.

Perhaps one of the most indicative, yet often overlooked statistics is the accuracy of each vehicle's projected performance. More accurate predictions generally indicate better knowledge of the vehicle's abilities due to more testing and more pre-race road time. This translates directly into better reliability and a more effective race strategy. Table 1 shows the predicted and actual average speeds for several of the 1990 World Solar Challenge entrants. The winners of both the 1987 and 1990 World Solar Challenge races were very accurate in their predicted speeds and daily mileages, while slower cars made correspondingly less accurate predictions.

The above ideas relating to potential and actual vehicle performance have influenced us greatly and we have adopted a set of 'project philosophies' in order to implement what we have learned:

- 1) Design, fabrication, testing, and driver training are equally important aspects of the project and are given equal priority and time. Many previous projects have not achieved their full potentials due to neglect of one or more of these critical areas.
- 2) Producing and racing a successful vehicle is the result of a coordinated effort between

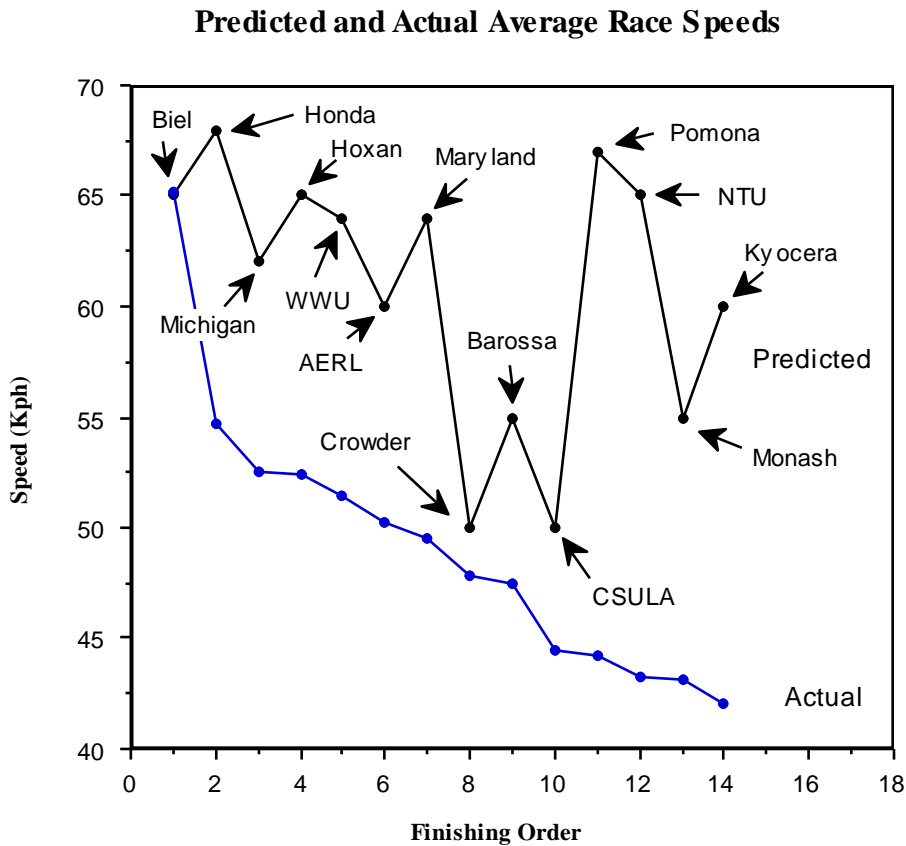

Figure 3

numerous individual project members with varying interests, skills, and levels of commitment. We recognize the importance of maintaining a coherent project organization with attention paid to inter-group communication, decision making, and compromise.

- 3) We will attempt to learn from, but not simply copy previous solar vehicle designs and race strategies. We will maintain a fresh perspective and entertain new and innovative ideas.

4) While we fully intend to build a winning vehicle, we hope to do so with an innovative design and competent race strategies rather than a multi-million dollar budget. We feel that it is counter to the promotion of solar power and environmentally clean transportation to rely on deep pocket financing.

II. Vehicle Design

Body design:

Figure 4 shows the general body design of the Montana State University solar vehicle. Factors which led to this design are:

- 1) low aerodynamic drag forces
- 2) crosswind stability
- 3) cockpit and array cooling
- 4) minimum material weight
- 5) minimal self shading of solar array
- 6) minimal aspect variation for series connected cells
- 7) minimal non-active surface area
- 8) one sun operating point on entire 8 sq. meter aperture
- 9) ease of construction

Point (6) is discussed in Section 3 on the solar array. Points (7), (8), and (9) require elaboration here:

Point (7): The body is designed for streamlined, attached airflow with zero lift and side forces, and therefore, zero induced drag force. The major remaining aerodynamic drag force is surface friction, which is minimized by an exceptionally smooth surface and low overall surface area. Any section of vehicle surface which is not power producing (e.g., not part of the solar array) is therefore detrimental to the vehicle's performance and should be minimized. Several past vehicles have taken advantage of surface area minimization to various degrees. The 1990 MIT Galaxy and 1990 Spirit of Biel both reduced their surface areas at the cost of loss of some array area to the driver's windshield. Both vehicles, however, were very successful, which points to the importance of reduction of aerodynamic drag forces even at the expense of some solar collection. The Montana State University vehicle, shown in Figure 4, is designed specifically to minimize non-active drag area without reducing the size of the solar array.

Point (8): Non-concentrator cells are typically designed for maximum efficiency at or near one sun (1000 Watts/sq. meter) illumination. Higher insolation levels produce higher currents producing relatively higher series resistance and recombination

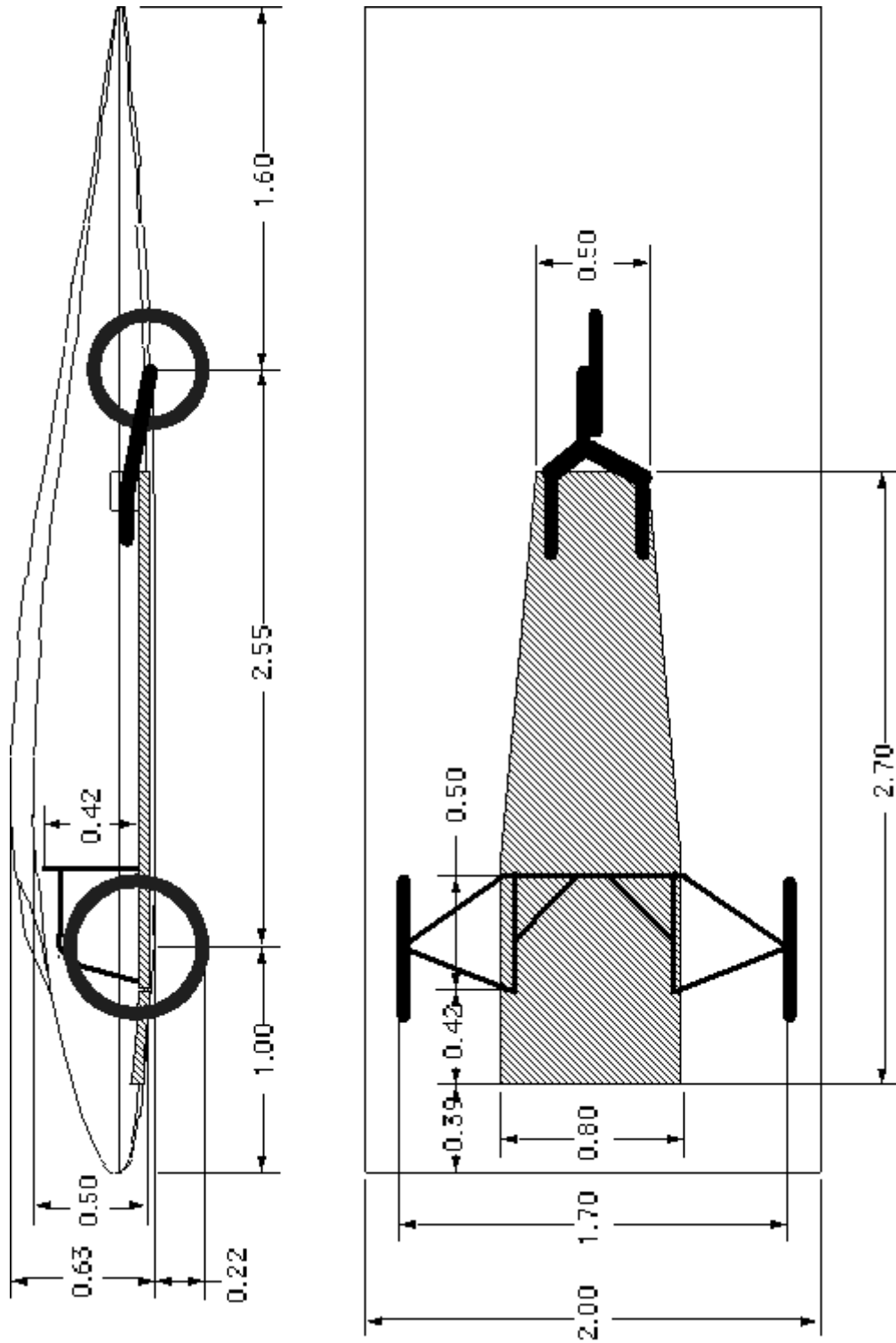

Figure 4

losses. Lower insolation levels produce lower currents, and thus incur unnecessary shading due to excessive front side metalization. Highest array efficiencies are therefore obtained with a flat array oriented normal to the incident radiation. Such a configuration also allows antireflection coatings to operate properly, and minimizes grazing reflection losses as might be expected on the sides of a curved array such as, for example, the GM Sunraycer or the Cal Poly Pomona Solar Flair. The disadvantages of a flat array as opposed to a curved array are slightly higher drag area and higher cross wind drag coefficient. However, as mentioned in section 1 above, array power is a higher priority design factor than aerodynamic efficiency.

Point (9): The array portion of the MSU solar vehicle is composed of four singly curved surfaces. In addition to the power advantages mentioned in point (8) above, this design eliminates the need to construct a full size mold, and enables much faster fabrication of the vehicle shell. These sections are to be constructed of .25 inch carbon/aluminum composite flat sheets, bent and bonded in place over a few cross ribs. Such flat sheets can be fabricated in a platen press enabling significantly higher stiffness to weight ratio than the alternative wet lay-up technique required for doubly curved body shells. This enables thinner, lighter structures and provides for better cooling of the solar array through the thin substrate.

Aerodynamic Analysis:

The main forces opposing the motion of a well built solar powered vehicle are rolling resistance due to deformation of the tires at the road surface and aerodynamic drag. At speeds above about 25 miles per hour, aerodynamic drag forces dominate, and it is therefore imperative that the vehicle's fairing, wheels and wheel wells, and cooling systems be designed to minimize these forces. Aerodynamic drag can be decomposed into several forces including induced drag, skin friction, and pressure drag. Aerodynamic performance is usually quoted as the "equivalent flat plate drag area" which is defined as the area of a flat rectangular plate, oriented perpendicular to the direction of motion, which has the same drag force as the vehicle. Well designed airfoil sections may have equivalent flat plate drag areas which are a small fraction of their actual frontal cross section area. Computer analysis of our body design predicts an equivalent flat plate drag area of just 0.13 sq. meters (the drag area of the actual vehicle may be somewhat higher due to cooling ducting and interference drag at the wheel wells). This value is comparable with those of the GM Sunraycer (0.135), the Spirit of Biel (0.13), and the Honda Dream (0.134). Figure 5 shows the predicted power consumption for various road slopes as a function of vehicle speed. It is seen that on a flat road surface, the vehicle will achieve 40 miles per hour on about 1.5 horsepower (1119 watts). Figure 5 also shows plots of motor efficiency which are discussed below.

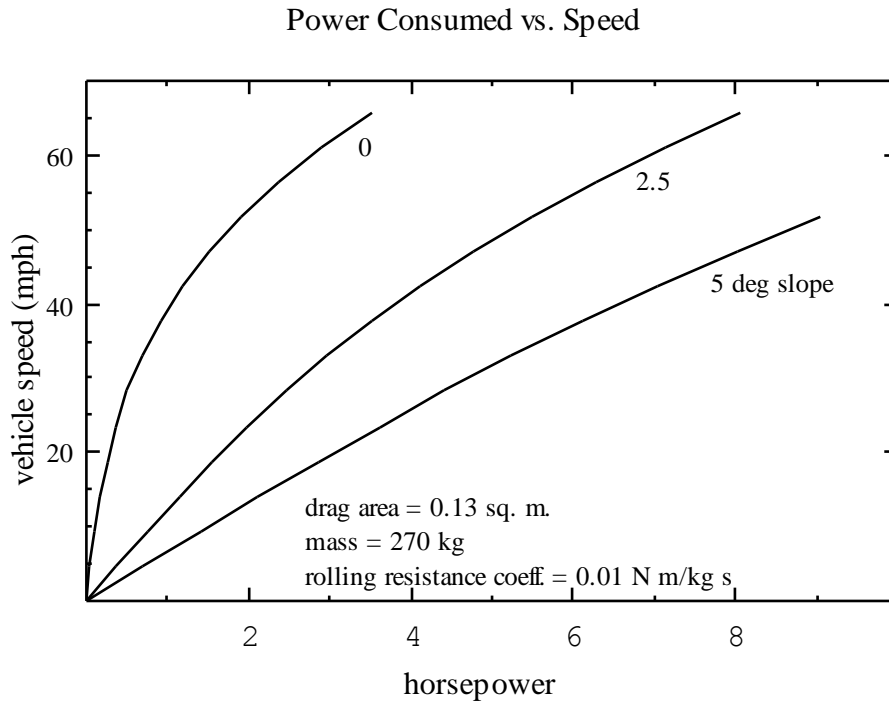

Figure 5

Suspension:

We have chosen a three wheel chassis design. Three wheel designs may be made lighter than four wheel designs, and the drivetrain mechanisms may be made significantly simpler. The four wheel design would be somewhat more stable during hard cornering and heavy cross winds; however the car is not intended to be entered in "Tour de Sol" style races which require strong cornering ability. Crosswind forces expected for our integrated body design do not require the added stability of a fourth wheel. The front suspension is a double "A-arm" configuration while the rear is a single-sided swing arm which enables fast tire and drive gear replacement. Front wheels are 26" x 1.25", 52 spoke bicycle wheels, rear is 20" x 1.25". Ultra -low rolling resistance (low hysteresis molded rubber) Michelin tires are used. For fast tire changes, all wheels are mounted on quick release hubs designed and built by members of the MSU Mechanical Engineering Department. Low viscosity synthetic grease is used in all wheel bearings. Light weight co-polymer shock/spring assemblies, designed and built at MSU, are used on all wheels.

Brakes:

Requirements for the braking system include positive stopping power, light weight, compact packaging, and efficient drag free operation. Hydraulic disc brakes have been chosen for the front wheels, while regenerative braking, which uses the motor as a generator to recharge the batteries, will be used on the rear. Because of the hub design necessary for use of bicycle wheels, limited space is available for brake discs and calipers. A compact caliper design is therefore necessary in order to prevent mechanical interference between the brake calipers and wheel spokes. In addition to this compact design, we require adequate stopping power for our 600 pound vehicle which may travel

at speeds in excess of 60 mph. In order to provide for efficient operation of the vehicle under cruising conditions, the front calipers must be fitted with pad retraction mechanisms, such that power is not needlessly dissipated in friction between the disc and pads. Many brake systems have been studied, and we have found that Performance Machine's 125x2 calipers with lightened 8.5" discs actuated by 5/8" hand operated master cylinder best satisfies our requirements.

Chassis:

Perhaps the most significant departure from previous solar car designs is our use of a "plank" chassis shown in Figure 6. The main load bearing component is a two inch thick carbon/nomex composite plank which also comprises the underside of the vehicle, and to which suspension components, batteries, and drivetrain are mounted. Such a chassis has several major advantages to tubular space frame, or torque ladder alternatives used in virtually all previous solar cars. These advantages include a large increase in useable interior volume, a significant savings in weight due to the plank's ability to perform several functions (i.e., the chassis, the bottom fairing, component mount points, driver seat, etc.), and ease of construction in a platen press with little subsequent bonding or joining of separate chassis pieces.

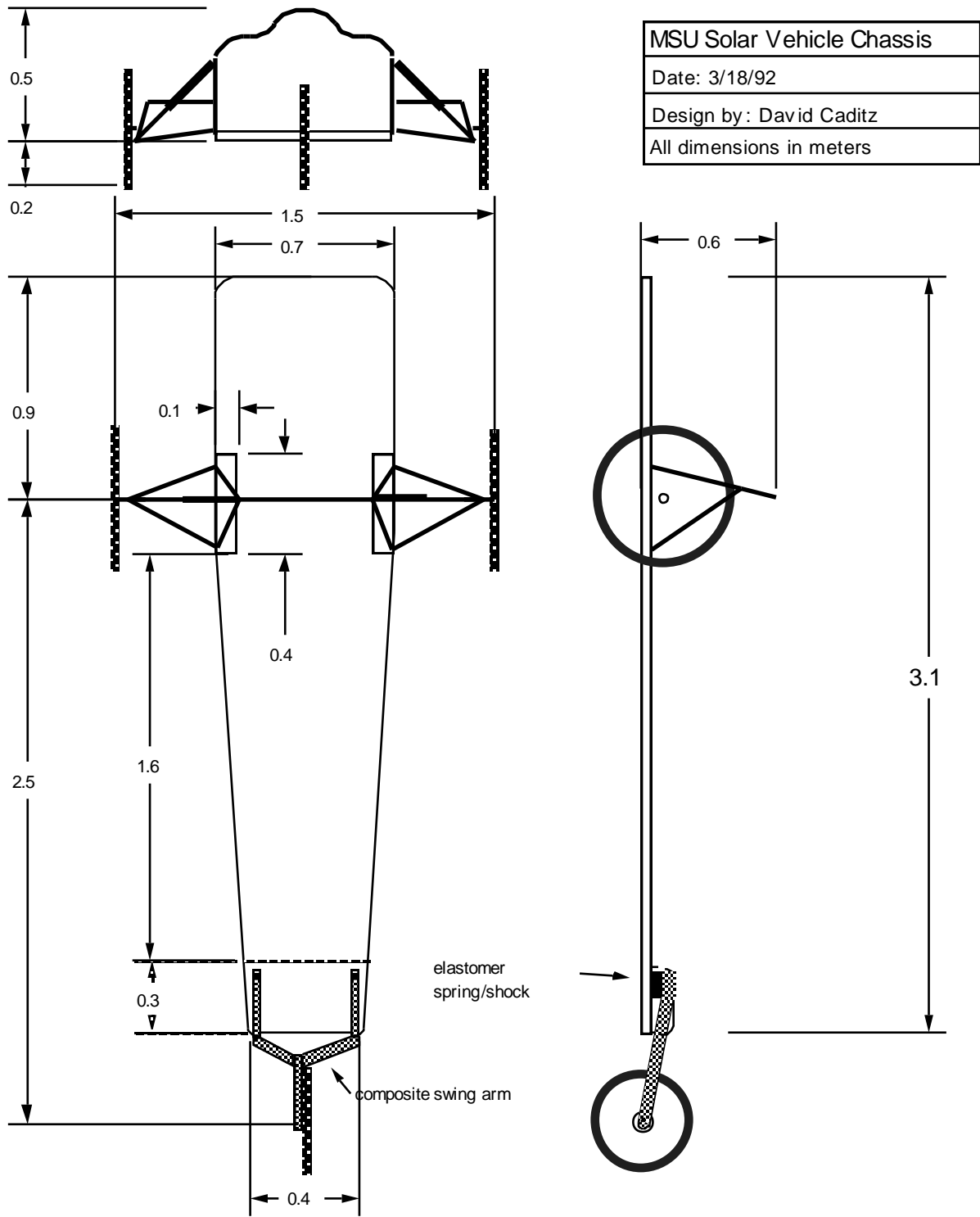

Figure 6

Motor/Drivetrain:

As of the time of writing of this proposal, we have not made a final selection of drive motor. Off the shelf possibilities include Uniq Mobility and Brusa permanent magnet brushless DC motors which typically have efficiencies of 85-92 % at our anticipated continuous operating point of 1.5 horsepower. We are presently evaluating a brushless motor with field control from American Motion Systems and a brushless DC motor with ferrofluid type bearings, both of which promise higher efficiencies.

Motor efficiencies will typically depend on motor torque, rpm, and operating temperature, and it is imperative to choose the drive gear ratio to maximize motor efficiency for the expected race speeds and terrain. Choice of gear ratio can be made with the help of motor efficiency curves such as those shown for the Uniq Mobility DR127 in Figure 7. From Figure 5, we see that for a speed of 40 mph (672 rpm at the drive wheel) on a level course, we expect to use about 1 horsepower (746 watts). The motor efficiency is highest at this power at about 2000 rpm, thus, a drive gear reduction of 3:1 is optimum. By the same reasoning, a ratio of 8:1 or higher would be necessary on a hilly course, or in strong headwinds.

We are presently considering fixed ratio chain and belt drives to transfer power from motor to drive wheel and to provide the necessary gear reduction to allow the motor to operate at peak efficiency. While both drive systems may achieve peak efficiencies in excess of 95%, actual or average efficiencies may be greatly reduced during realistic race conditions. Major factors contributing to drivetrain inefficiency are chain or belt twisting and misalignment, improper tensioning, and the build-up of road grime. Other concerns are ease and speed of drive gear changes, drivetrain weight, and aerodynamic drag induced by the drive wheel. On hilly courses, it may be advantageous to introduce a transmission which would allow the motor to operate at maximum efficiency at various horsepower ranges. At this time, such transmissions are heavy, inefficient, and complicated; however, because a transmission would give a significant advantage, we are monitoring advances in transmission technologies.

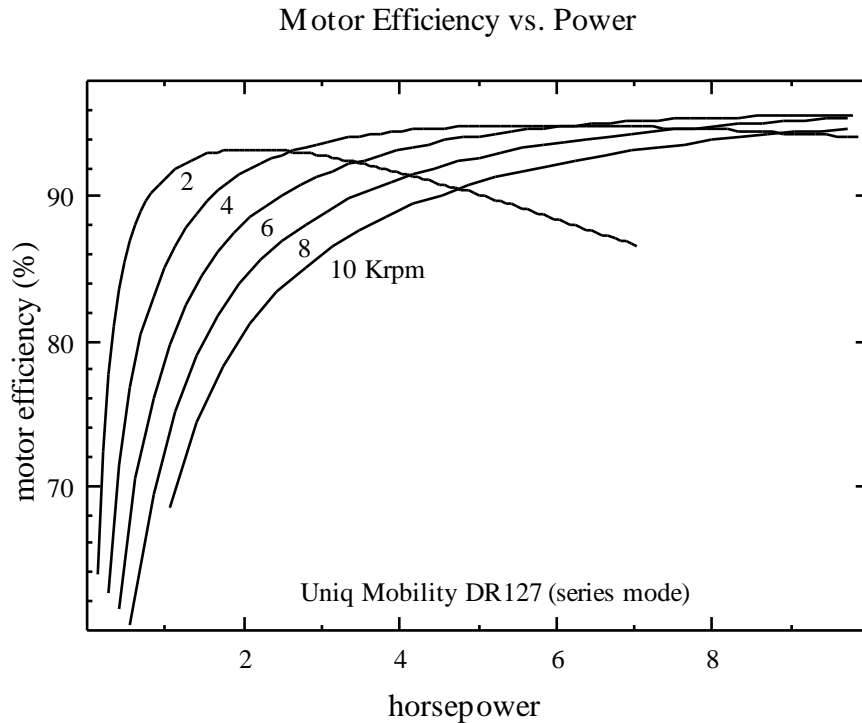

Figure 7

Power, Monitoring, and Control Electronics:

The electrical system is designed to provide safe and efficient transfer of power between the solar array, batteries, motor controller, and motor, to maintain adequate control and operating conditions for various vehicle components, and to provide for monitoring of the vehicle performance via readouts in the cockpit and radio telemetry to the chase vehicle. A vehicle wiring diagram is shown in Figure 8.

Batteries:

At the heart of the vehicle's electrical system are the batteries which store collected solar energy for acceleration, hill climbing, and periods of low solar illumination. The importance of efficient battery usage cannot be overstated, and it is our opinion that the performance of electric vehicles can be greatly improved by a better understanding of battery behavior. We are planning a vigorous battery testing program designed to produce an accurate computer based battery performance model suitable for inclusion in our overall strategy program described below.

Choice of battery type is determined by weight and size considerations, charge/discharge efficiency, cycle life, cost, race rules, and course. Silver-zinc batteries

have been used in several successful solar vehicles and they provide the highest energy storage to weight ratio and highest cycle efficiency of any readily available battery. Silver-zinc batteries, however, are especially sensitive to over-charging and discharging, and over-cycling, and careful management of these batteries is critical. Our battery model will enable us to predict and manage battery state of charge, and will enable us to utilize these batteries in the most efficient manner. In addition, batteries will be monitored via telemetry for signs of reduced performance or premature failure.

Maximum Power Trackers:

The maximum power trackers (MPTs) are designed to ensure that the solar array is operating at its peak efficiency under varying conditions of solar illumination, and to condition the power output to the batteries and motor controller. Several MPTs are commercially available, however, we feel that significant improvements could be made to these over the counter designs. For example, the Brusa PPT provides protection for battery overcharge by cutting off all array power when the battery voltage exceeds a preset maximum level. Since battery voltage is not necessarily a good indicator of state of charge, a great deal of potential array power may be lost. For this and other similar reasons, the MSU Electrical Engineering Department is designing a custom programmable MPT, based on a Motorola 68HC11 microcontroller unit. This MPT is software driven with the ability to measure input characteristics, such as, for example, battery temperature, amp hours, discharge rate, etc., to determine the optimal battery charging profile.

Auxiliary 12 Volt System:

A 12 volt system, powered by the main batteries through a DC-DC converter will provide power for all cockpit instrumentation, brake and turn signal lights, cooling fans, control board, and telemetry system.

Integrated Control Board:

Monitoring and control of electrical and mechanical systems will be accomplished with an integrated control board (ICB) designed and built by the Montana State University Electrical Engineering Department. The ICB, which is based on a Motorola 68HC11EVB microcontroller unit, will control all vehicle systems using sensor inputs, driver commands, telemetered commands from the chase vehicle, and internal software. As described below, the ICB will drive the cockpit display, giving the driver information such as vehicle speed, battery condition, motor efficiency, etc. as well as the telemetry system, for display and recording of vehicle data on a support computer. In addition, the MCU will compare sensor data with preprogrammed safe operating ranges, and warn the driver and chase vehicle of abnormal readings.

Driver Controls and Instrumentation:

Acceleration and regenerative braking commands from the driver will be monitored by the integrated control board, which will in turn output commands to the motor controller. This system allows programmable conditioning of the driver's commands based on sensor input such as e.g., motor temperature, battery state of charge, etc., and command inputs from the chase vehicle, allowing for safer and more efficient operation of the vehicle. Vehicle speed, bus voltage, motor current, and other systems information will be displayed on a programmable LCD dot matrix display in the cockpit. This flexible, software based system allows for greater information gathering capabilities and can display, for example, actual motor efficiency, based on real time sensor inputs and data manipulation in software.

Power Electronics Circuit Diagram

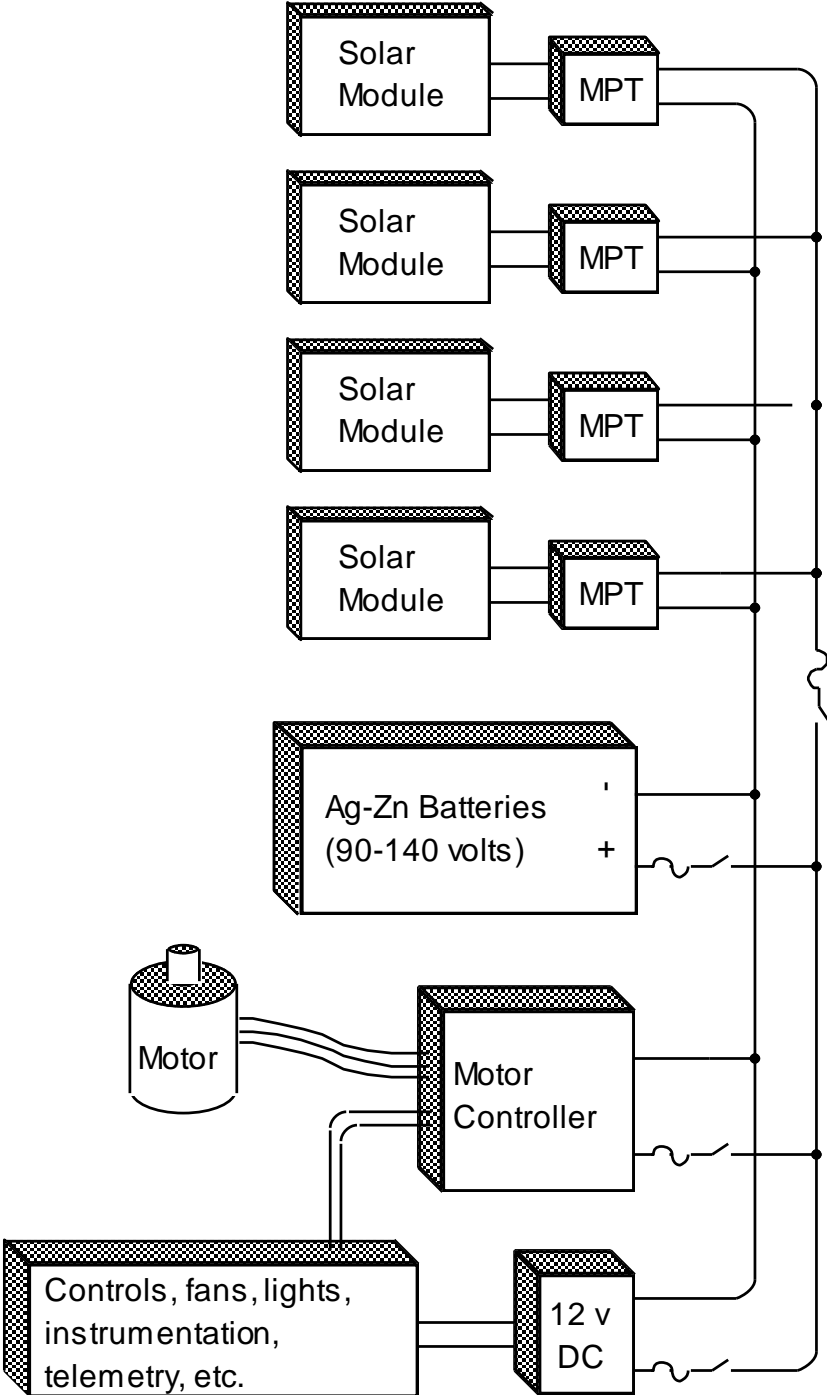

Figure 8

III. Solar Array

As described above, the most important single component of our solar race car is the solar array. Single seat race cars have been built with power generation capabilities between a few hundred watts to 1.5 kilowatts (module efficiencies from 2.5% to 18.75%) with vehicle performance varying accordingly.

Gallium Arsenide (GaAs) solar cells provide several advantages for solar vehicles relative to the more commonly used silicon cells. GaAs cells generally have higher photon absorption than silicon, and therefore higher energy conversion efficiencies. In addition, the higher band gap allows for efficient operation at higher temperatures and slightly less temperature sensitivity than silicon solar cells. The disadvantages include high cost and electrical and mechanical fragility.

Two solar cars have been built using GaAs cells: The 1987 GM Sunraycer had a mixed solar array with 80% GaAs cells and 20% silicon cells which produced a peak power of 1500 watts (18.75% efficient) at 1000 watts per square meter insolation and at a cost in excess of \$10,000,000. The Sunraycer won the 1987 World solar challenge by a wide margin, and it still holds several speed records for solar powered vehicles. Cal Poly Pomona's Solar Flair was the second car to use GaAs cells, and the first to have a complete GaAs array. The Solar Flair's cells were donated by Applied Solar Energy Corporation, and ranged in efficiency from approximately 12% - 20%. Cell testing and sorting was thus very critical, and ASEC helped Cal Poly with this and other steps of the module's fabrication. Unfortunately, as discussed above, the Solar Flair was beleaguered by mechanical problems during the 1990 World Solar Challenge (see Figure 2) and finished in 11th place, well below what might have been expected given its power/weight ratio. Crowder college and Virginia Tech both attempted to build GaAs arrays, but were apparently unsuccessful due to time constraints and fabrication problems.

It is reasonable to assume an array efficiency of 16%-18% for GaAs cells donated by ASEC with a conservative estimate of daily average output power of 1000 watts. For a power/weight ratio equal to the Sunraycer, our vehicle would have to weigh 162 Kg or about 18 Kg less than the Sunraycer. We feel that this is an achievable goal, and that our plank chassis will contribute greatly to the required weight savings. For comparison, the 1990 World Solar Challenge had at least 12 entries which were lighter weight than the Sunraycer, the lightest being Honda's Dream at 138 Kg. In addition, recent advances in aerodynamic design, power electronics, and race strategy help to provide more overall performance for a given solar array power.

The performance and durability of the solar array depend both on the quality of the individual cells and on the module design and fabrication techniques. We hope to obtain a sufficient number of high quality (> 18% efficient) Ga-As solar cells to form the basic elements of our high efficiency custom solar array. Important module design factors include

- 1) cell sorting/current matching
- 2) interconnect current capacity
- 3) interconnect attachment method
- 4) cell bypassing
- 5) cell encapsulation
- 6) cell cooling
- 7) module substrate rigidity
- 8) module substrate thermal & electrical conductivity
- 8) active area coverage ratio
- 9) routine module cleaning
- 10) electrical design, voltage/current operating points
- 11) electrical circuit routing
- 12) cell orientation with respect to the sun
- 13) cell covers/refractive index/AR coating
- 14) power point tracking
- 15) thermal matching of substrate, cells, interconnects, covers
- 16) ease of repairability
- 17) module weight

Due to the electrical and mechanical fragility of gallium arsenide solar cells, especially critical factors from the above list are substrate rigidity, interconnect attachment, electric circuit design and bypassing.

In order to reduce weight, increase array efficiency, and assure maximum possible active area, a custom solar module will be constructed for the MSU solar vehicle. The MSU Solar vehicle has an integrated body and solar module design. The vehicle's body fairing doubles as the module substrate. The general module design is shown as the cross-hatched area in Figure 4.

A cross-section through the module is shown in Figure 9. The module substrate is a light weight composite structure composed of laminated high modulus unidirectional carbon fiber face sheets bonded onto an aluminum honeycomb core. The aluminum core is chosen over nomex or foam cores in order to increase thermal conductivity through the substrate, and thus improve array cooling. In order to reduce the possibility of electrical shorts on the conductive carbon face sheets, a 1 mil layer of kapton film is laminated to the outer face sheet of the substrate. The entire substrate is formed from singly curved segments which are produced in a heated platen press. This system produces a light weight, yet rigid structure, which protects the fragile solar cells from mechanical stresses. Due to the plank design, the major torques and stresses produced at the suspension hard points are not transmitted through the module substrate.

The solar cells are mounted onto the completed substrate using a two part thermally conductive RTV adhesive. The cured RTV remains pliable and is thus able to absorb any mechanical stresses within the module produced by differential thermal expansion or substrate flexure. Array cooling is also improved with the thermal conductive RTV compared to double sided tape which is commonly used to mount cells on solar cars.

Cells are protected from weather and road grime with 6 mil anti-reflection coated glass covers. The anti-reflection coating is broad band nonsoluble Magnesium Fluoride with greater than 98% transmission over a wide range of frequencies and angles of solar incidence. Individual covers are fastened to each cell using flexible two part optical grade RTV adhesive.

Factors important to the electrical design of the module are cell matching, common orientation with respect to the incident light of series connected cells, lengths of series connected strings, and cell bypassing. The current produced by a series connected string of cells is limited by the poorest cell in the string, and it is therefore necessary to sort and match the cells before connecting them into strings. For a similar reason, all cells in a given string should receive the same incident sunlight, and therefore should be pointing in the same direction relative to the sun. For the above reasons, and for reasons of dependability, relatively short series connected strings are advantageous. However, short strings mean low voltage, which must be boosted by the maximum power trackers (MPT) up to the battery voltage of 140 volts. MPT tests show voltage boost efficiencies in excess of 95% for array voltages as low as 50 volts, and therefore, we set our nominal string voltage at approximately 75 volts at maximum power under full sunlight, or about 150 cell series connected strings. the final string length will be determined by the number of individual cells which fit easily onto the substrate width.

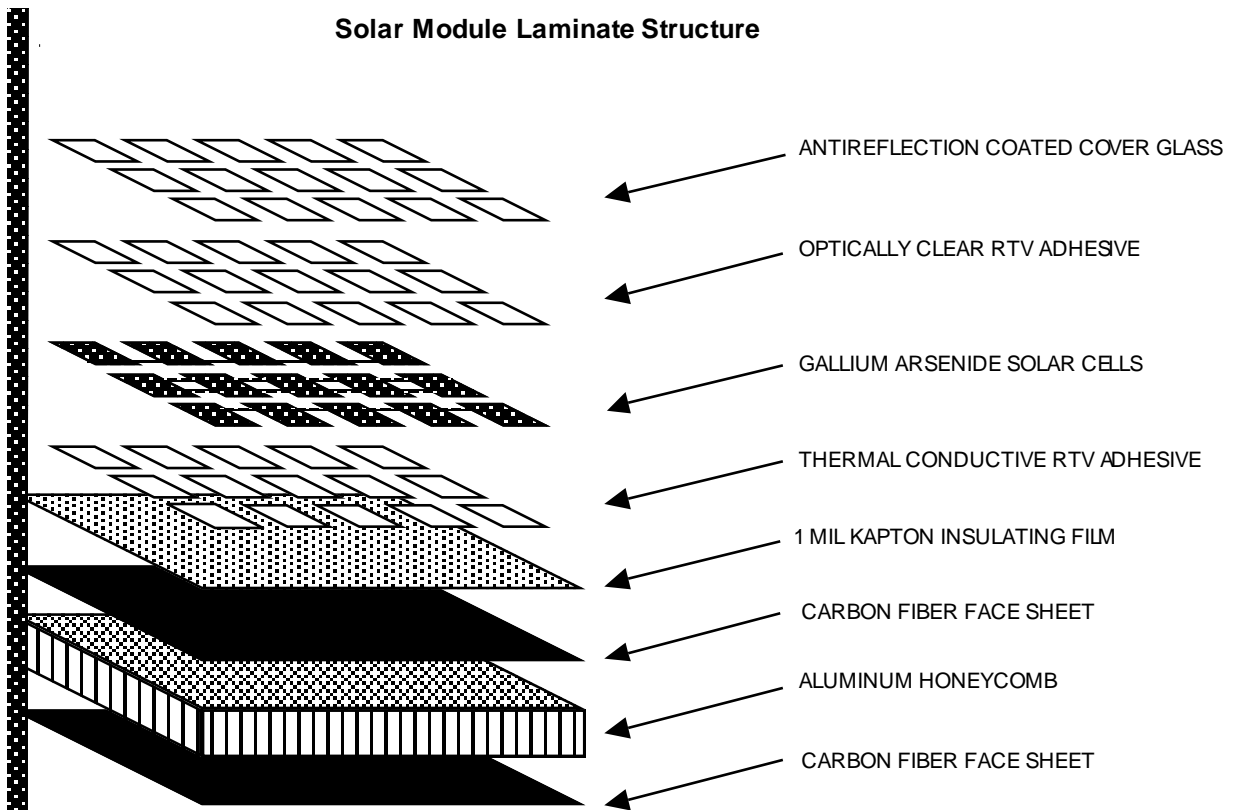

Figure 9

In order to protect the cells from reverse bias due to shading, and to prevent the failure of a single cell or solder joint from eliminating an entire series connected string, diodes are mounted, bypassing every five cells. This point is especially critical with gallium-arsenide solar cells which are susceptible to reverse bias damage. We are presently considering the use of light emitting bypass diodes (LED's) so that a string failure may be immediately detected without need for test equipment or probing of the array. LED's are mounted on the back side of the substrate (inside the vehicle body) so that they don't take up valuable active area on the solar array.

The above described module design has been tested thoroughly (using silicon cells) and it is found to be durable, light weight, and to provide high optical and electrical efficiencies.

IV. Vehicle Testing, Driver Training, and Race Strategy:

As mentioned in section 1 above, when our vehicle is completed, our job is only half finished. We are planning a rigorous program for vehicle testing and accurate characterization of vehicle performance. These tests will enable us to work out inevitable bugs, to determine fast and efficient maintenance and repair procedures, and to learn the most efficient ranges of operation of the vehicle under various conditions.

The overall race strategy will be determined with the help of a detailed strategy computer program written by members of the MSU computer science department. This program contains performance model of the vehicle based on rigorous testing and measurements of e.g., aerodynamic drag and rolling resistance coefficients, motor efficiency as a function of torque, rpm, and temperature, array efficiency, etc. In addition, the race course will be digitized and included in the strategy program. The strategy program will then be run with a variety of likely weather conditions and a library of optimal velocity profiles developed. The actual and predicted weather conditions during race time will dictate which velocity profile will be chosen, and the profile will be constantly updated as weather and vehicle performance information is collected.

Equally important to overall race performance are our so called "micro-strategies". Micro-strategies address the optimal methods for negotiating small scale features such as, for example, accelerating from a stop light or around a curve, negotiating small hills or rolling terrain, speed profiles through scattered clouds, and other unpredictable situations. Such situations will be encountered constantly along the course, and they are too numerous to be included in the overall strategy program. To address these situations, a program of driver training will be undertaken to help the drivers develop insight into the best micro-strategies. This program will include computer simulations of likely situations which drivers may "drive" using various proposed strategies, as well as miles of actual behind the wheel driving with performance monitored and recorded via the telemetry system. Drivers will be compared for overall efficiency on a representative race course and the habits of the best drivers will be discussed in the driver pool.

V. Fundraising

Because most of the components comprising our solar car are custom designed, hand made, and low volume items, the cost of the project will be considerable. Our project budget is detailed below. The budget is divided into cash and in kind donations, and we indicate those companies which have agreed to donate needed components, or from whom we hope to obtain donations. We point out that all project members work on a volunteer basis, and the budget contains no salaries or personal compensation for project members.

Our fundraising committee has been working in conjunction with the Montana State University Foundation to obtain cash donations from local and national industry, alumni, and other interested individuals. Since the formation of our project, we have experienced a great deal of local community and statewide support. We have held several fundraising events, and we are well on our way to collecting the necessary cash portion of our budget.

Our overall fundraising plan was initiated shortly after project formation, and it will continue throughout the construction and racing of the vehicle. The plan calls for accurate and current cost estimates, documentation of actual income and expenditures, identification and solicitation of private and industry related donors, donor relations including project updates, newsletters, and publicity for sponsors, and carrying out fundraising events. Our seven member fundraising committee is highly motivated, and ready to take on the challenge of obtaining funding for this exciting project.

**Montana State University Solar Vehicle Project
Budget for Construction of Solar Race Vehicle**

Item	Supplier	Cash	In Kind
Fabrication:			
Batteries Lead-Acid	Eagle Picher	\$1,000	
Solar cells	Sunpower	15,000	
Solar cell adhesives	Dow	500	
Solar cell covers	OCLI	1,000	
Kevlar/Graphite	DuPont/Ciba-Geigy		\$15,000
Nomex/Al Honeycomb	Hexcel		10,000
Wheels/Hubs	Norm Williams	1,500	
Suspension/Shocks		1,000	
Steering		500	
Lexan Windshield	GE/Zzip Designs		500
Cockpit Controls		500	
Radio/Telemetry		3,000	
Monitoring Electronics		500	
Power Trackers		2,000	
Brakes	Performance	1,000	
Motor/Controller	MFM	2,000	
Wiring	Raychem		1,000
12 V System		500	
Molds		1,000	
Fabrication Total:		\$31,000	\$26,500
Business:			
Fax		500	
Publications		500	
Photography			500
Mailing/Shipping		700	
Phone		1,000	
Travel		3,300	
Business Total:		\$6,000	\$500
Contingency Fund		5,000	
Grand Total:		\$42,000	\$27,000

VI. Project Organization

The Montana State University Solar Vehicle Project is relatively small with approximately 10 members. We have divided the project into several sub-groups including chassis/suspension, body shell, solar array, electronics, race strategy, and fundraising. Project members are assigned to one or more groups based on their primary abilities and interests, however, because of inherent overlap between the responsibilities of many subgroups, members are encouraged to participate in the activities of all other divisions. Intera-project cooperation and communication is considered to be of the utmost importance.

VII. Member Biographies

David Caditz, Ph.D. - Faculty Advisor.

B.S. Physics from Massachusetts Institute of Technology, 1983. Ph.D. in Astrophysics from Stanford University, 1992. Presently an assistant professor at Montana State University. Dr. Caditz has been active in the design, construction, and racing of solar powered vehicles for the past six years. He was the director of the 1991 California Clean Air Race, and head driver for the Stanford Solar Car Project. Dr. Caditz designed and constructed the solar array of the very successful 1990 Stanford SUNSurfer solar race vehicle.